



CARATTERISTICHE PRINCIPALI

- ✓ VANO CONTENITORE
- ✓ RETE DOPPIA APERTURA
- ✓ DOLPHIN SURROUND
- ✓ LUCI LED

MAIN FEATURES

- ✓ STORAGE COMPARTMENT
- ✓ DOUBLE-OPENING NET
- ✓ DOLPHIN SURROUND
- ✓ LED LIGHTS

FABIOLA è il letto dal design moderno e dalle linee semplici. La sua struttura imbottita accoglierà il materasso in modo naturale e donerà raffinatezza alla camera da letto. La forma essenziale della testiera è arricchita da due maxi cuscini che aggiungeranno movimento ed eleganza. Sfruttando la combinazione dei rivestimenti in vera pelle o tessuto lo si potrà abbinare nel modo desiderato. La possibilità di scegliere la rete a doppio movimento doterà il letto di un vantaggioso contenitore e la camera di una proficua organizzazione degli spazi.

FABIOLA is the bed with a modern design and simple lines. Its upholstered frame will naturally accommodate the mattress and give sophistication to the bedroom. The essential shape of the headboard is enhanced by two maxi pillows that will add movement and elegance. Taking advantage of the combination of genuine leather or fabric upholstery you can match it the way you want. The possibility of choosing the double-movement bed base will provide the bed with advantageous storage and the room with profitable space organization.

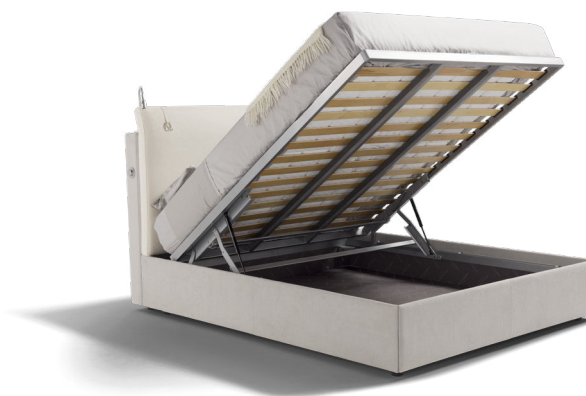

SPALLIERA RIALZATA DOLPHIN SURROUND E LUCI LED
Dolphin Surround raised backrest and LED lights

VISTA LATERALE
Side view

VISTA FRONTALE
Front view

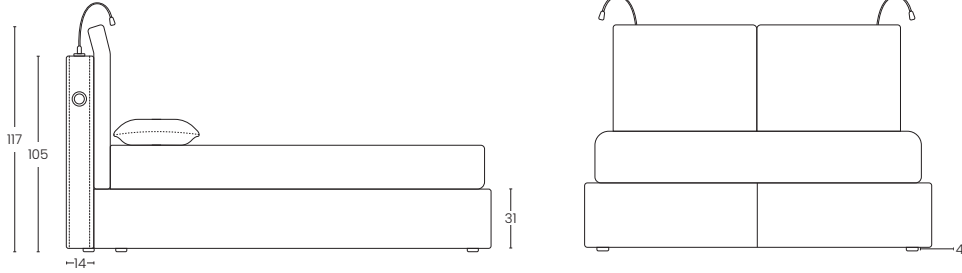

LETTO SINGOLO
single bed

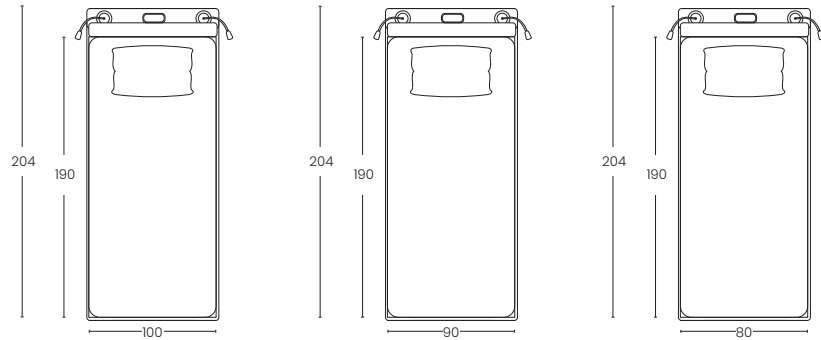

LETTO MATRIMONIALE
double bed

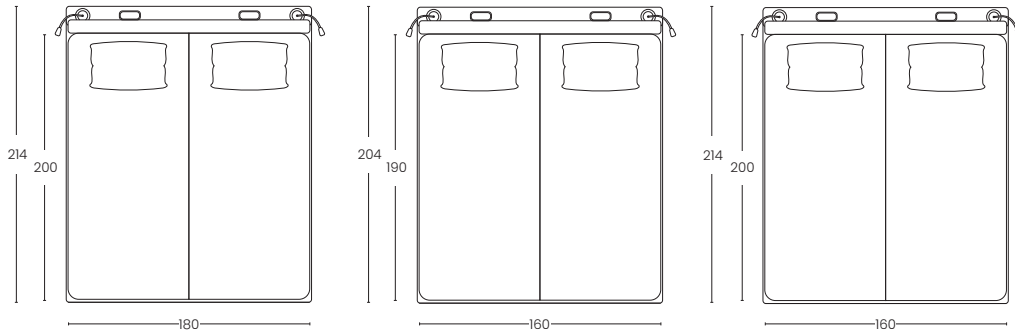

SPALLIERA SLIM
slim backrest

VISTA LATERALE
Side view

VISTA FRONTALE
Front view

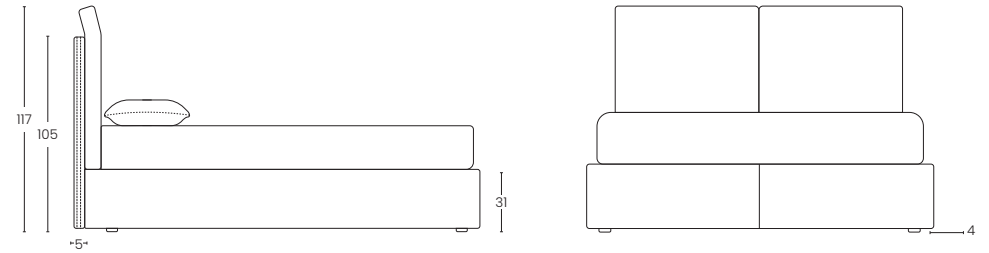

LETTO SINGOLO
single bed

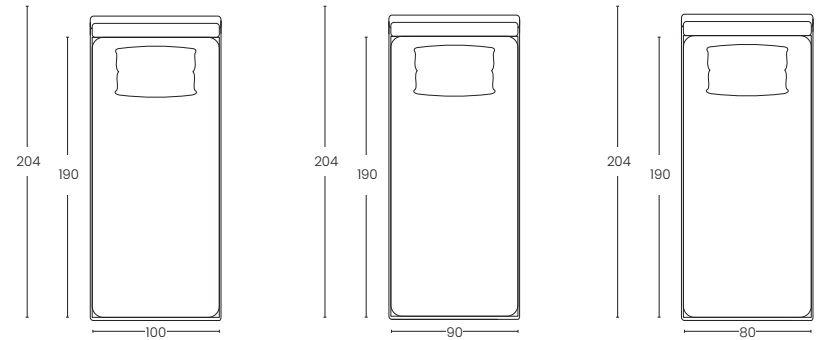

LETTO MATRIMONIALE
double bed

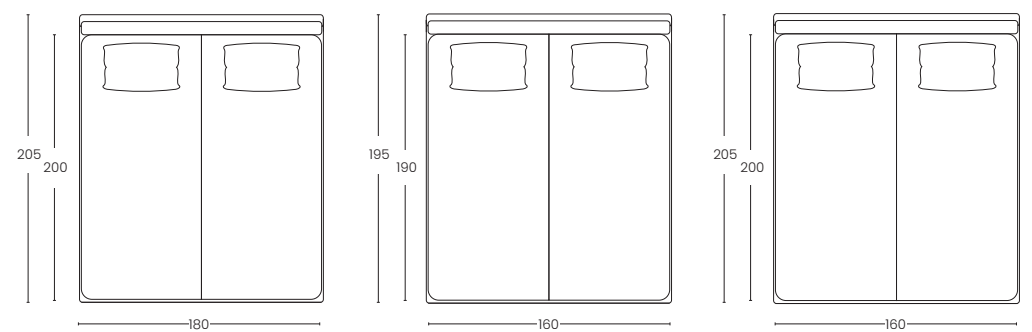

BLUETOOTH AUDIO SYSTEM *bluetooth sound system*

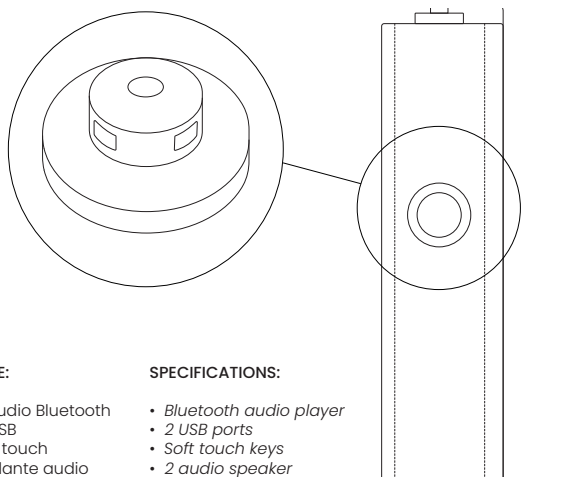

SPECIFICHE:

- Lettore audio Bluetooth
- 2 porte USB
- Tasti soft touch
- 2 altoparlante audio
4Ω 10W speaker power

SPECIFICATIONS:

- *Bluetooth audio player*
- *2 USB ports*
- *Soft touch keys*
- *2 audio speaker*
4Ω 10W speaker power

SUBWOOFER SYSTEM *subwoofer system*

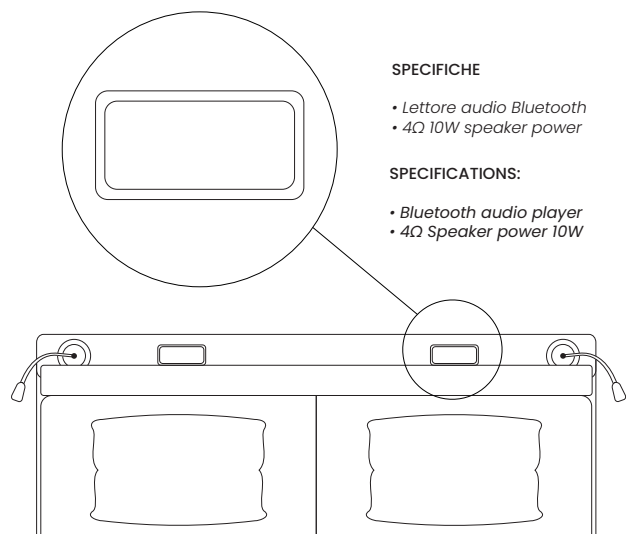

SPECIFICHE

- *Lettore audio Bluetooth*
- *4Ω 10W speaker power*

SPECIFICATIONS:

- *Bluetooth audio player*
- *4Ω Speaker power 10W*

ACCESSORI *accessories*

LAMPADA LED *Led lamp*

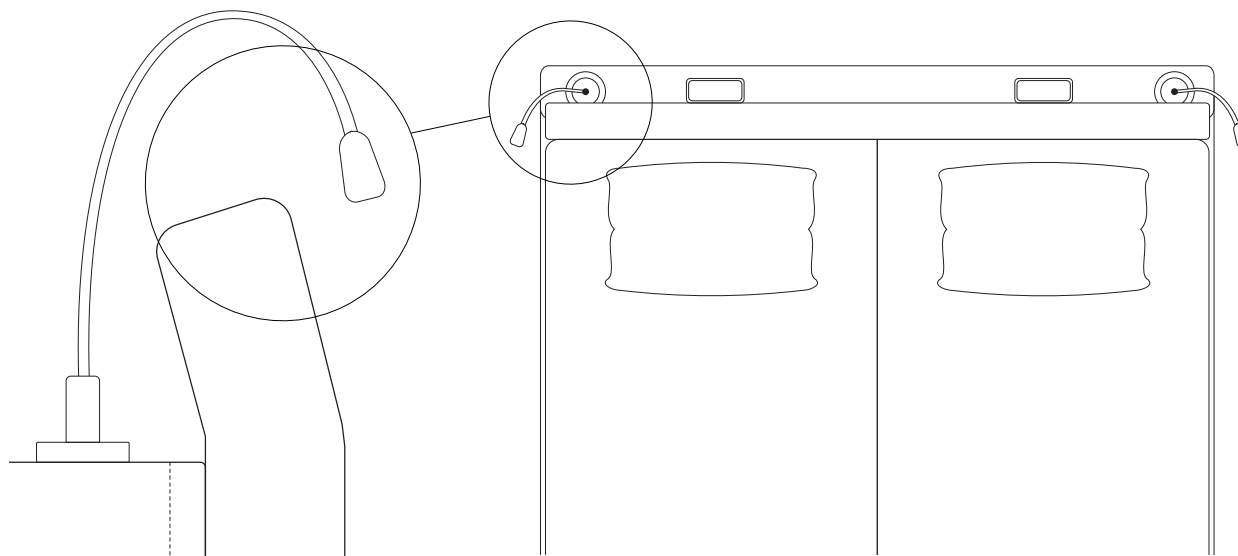

“Lampada LED removibile dotata di innovativa tecnologia touch e di una comoda presa USB integrata per la ricarica dei tuoi dispositivi mobili. Questo elegante accessorio, progettato appositamente per poltrone, divani e letti, unisce stile e funzionalità per offrire un’illuminazione personalizzata e la comodità di avere sempre a portata di mano un punto di ricarica per smartphone, tablet o altri dispositivi elettronici. Grazie alla sua praticità e alla sua versatilità, questa lampada è l’ideale compagna per le tue serate di relax e di intrattenimento domestico.”

“Removable LED lamp featuring innovative touch technology and a convenient built-in USB outlet for charging your mobile devices. This stylish accessory, designed specifically for armchairs, sofas and beds, combines style and functionality to offer personalized lighting and the convenience of always having a charging point for smartphones, tablets or other electronic devices at hand. With its practicality and versatility, this lamp is the ideal companion for your evenings of relaxation and home entertainment.”

SPECIFICHE

- *Illuminazione*
- *Controllo touch*
- *2 intensità di luce*
- *Porta USB per caricare*

COMPOSIZIONE

- *Lampada tubo flessibile (H 500 mm) L 205 mm*
- *USB box*
- *Trasformatore USB (100-240V - 5V/2A)*
60 cm x 40 mm x 70 mm

SPECIFICATIONS

- *Illumination*
- *Touch control*
- *2 light intensities*
- *USB port for charging*

COMPOSITION

- *Flexible tube lamp (H 500 mm) W 205 mm*
- *USB box*
- *USB transformer (100-240V - 5V/2A)*
60 cm x 40 mm x 70 mm